

NOVA

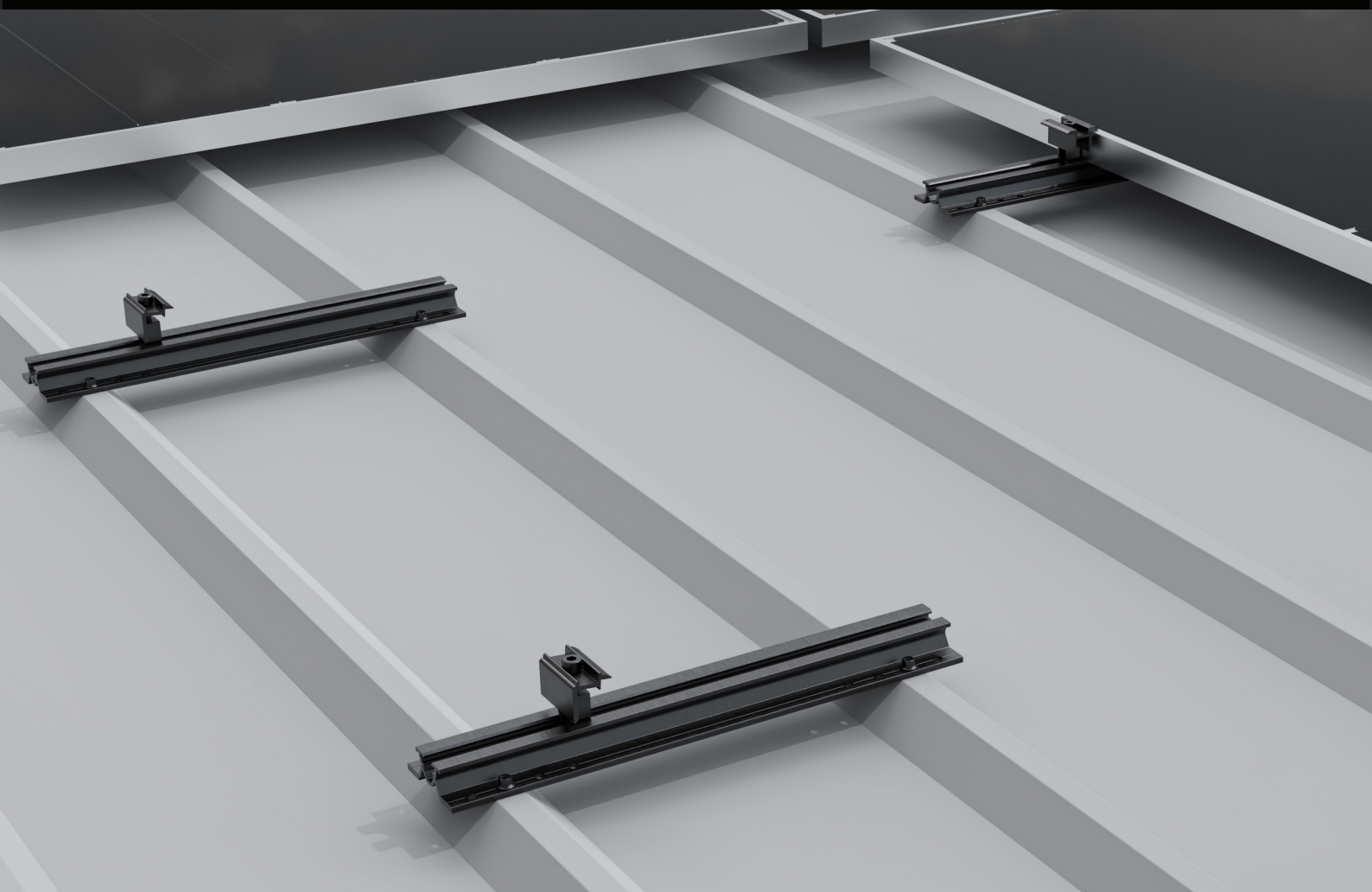

INSTALLATION MANUAL



Roof Mounting System

NOVA MINI RAIL

ARTICLE # 920-122310 / 920-122310-B



25 YEAR WARRANTY



UP-TO 30% FASTER INSTALLATION



PORTRAIT



REGINA WAUTERSWEG 13, 8800 ROESLARE BELGIUM

+32 (0)51 14 05 94

WWW.NOVAMOUNTING.COM

INTRODUCTION

Welcome to the NOVA Solar Mounting Solution Installation Manual. This guide is your comprehensive resource for installing NOVA's solar mounting systems. Designed with precision and engineered for durability, our systems ensure a seamless and efficient installation experience.

Whether you're working with penetrative tin roofs, tile roofs, or other specialised surfaces, this manual provides step-by-step instructions and all the necessary details to ensure a successful and long-lasting solar installation.

GENERAL RESPONSIBILITY & SAFETY GUIDELINE

Qualified Installers: Only qualified and trained personnel should install and operate the equipment. At least two people must be present during installation to ensure safety and provide assistance in case of an emergency.

Handling and Modification: Do not throw or roughly handle any components. Avoid bringing the system into contact with sharp or heavy objects. Do not modify components in any way, including exchanging bolts, drilling holes, or bending parts. Any such modifications not described in the standard installation procedure will void the warranty.

Compliance: Ensure compliance with national and local building regulations, health and safety standards, and environmental requirements.

Roof Inspection: Before installation, verify the roof's load-bearing capacity. Check that the roof is in good condition and can support the weight of the solar panels, including additional materials and loads.

Weather Conditions: Avoid installation in adverse weather conditions, such as strong winds or wet, slippery surfaces.

Safety Measures: Follow all fire regulations related to photovoltaic installations. Ensure the roof surface is clean, dry, and free of debris before beginning installation. Use safety nets and edge protection as necessary.

Earthing and Bonding: Perform equipotential bonding, grounding, and earthing according to country-specific standards and regulations.

Protective Gear: Wear appropriate protective equipment such as helmets, gloves, and non-slip safety boots.



TESTING & CERTIFICATION

All components have been tested and developed to be compliant with relevant guides and regulations.

INSTALLATION GUIDELINES

Ensure that the roof construction is suitable for the introduction of forces at the fixing points and their subsequent transmission. In order to compensate thermal expansion, include a break every 25 meters when planning the PV-system. For module positioning/fastening points please refer to manufacturers recommendations. Please follow your local timber construction standard. Please do not use installed roof connections as ladder. If installation is located within 10km from the coast, we advise not to use zinc coated material. For further information please contact your sales representative or the technical department at NOVA Mounting.

WARRANTY

Warranty according to the terms and conditions found on the website www.novamounting.com
NOVA is not accountable for the roof's capability to maintain the introduced forces. Please check the roof's compatibility with a static engineer.

Mini Rail system

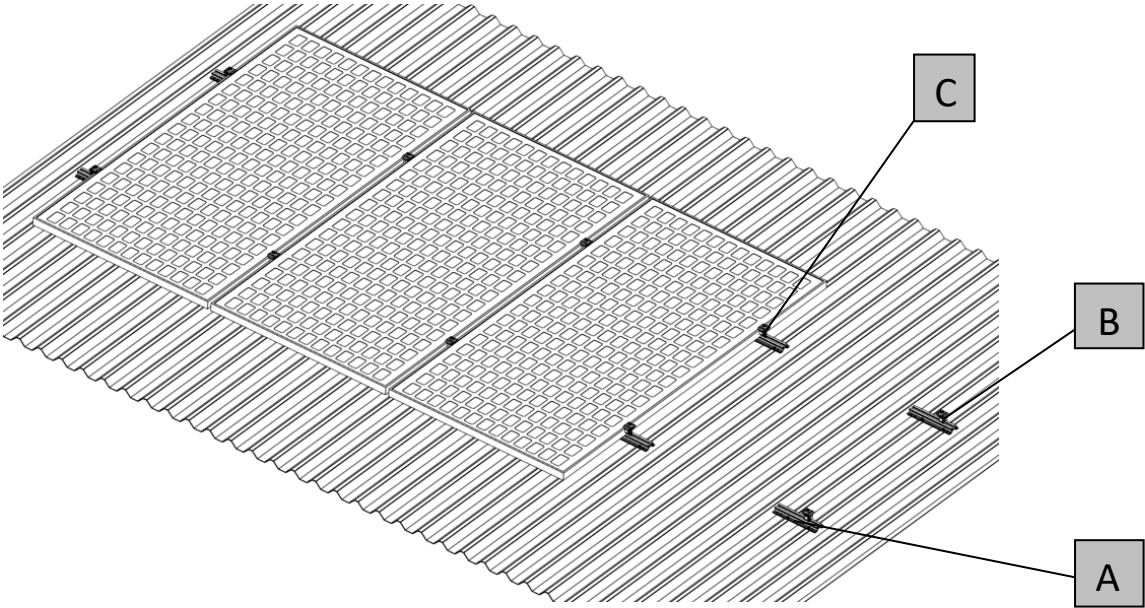

A

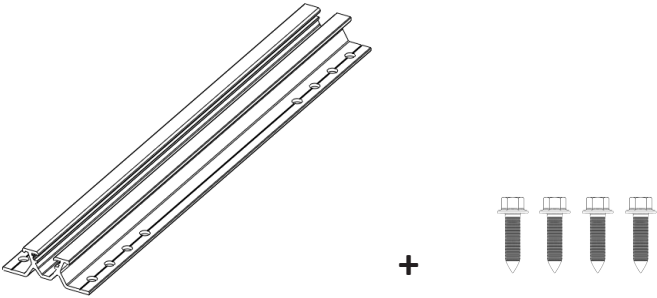

B

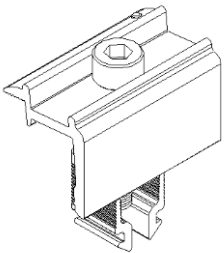

C

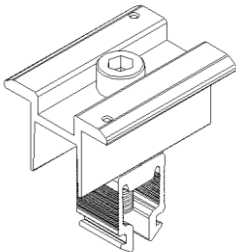

+



M8



13mm

Solar panel layout

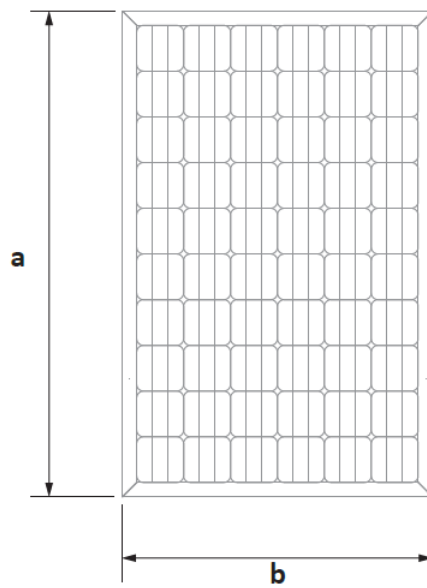
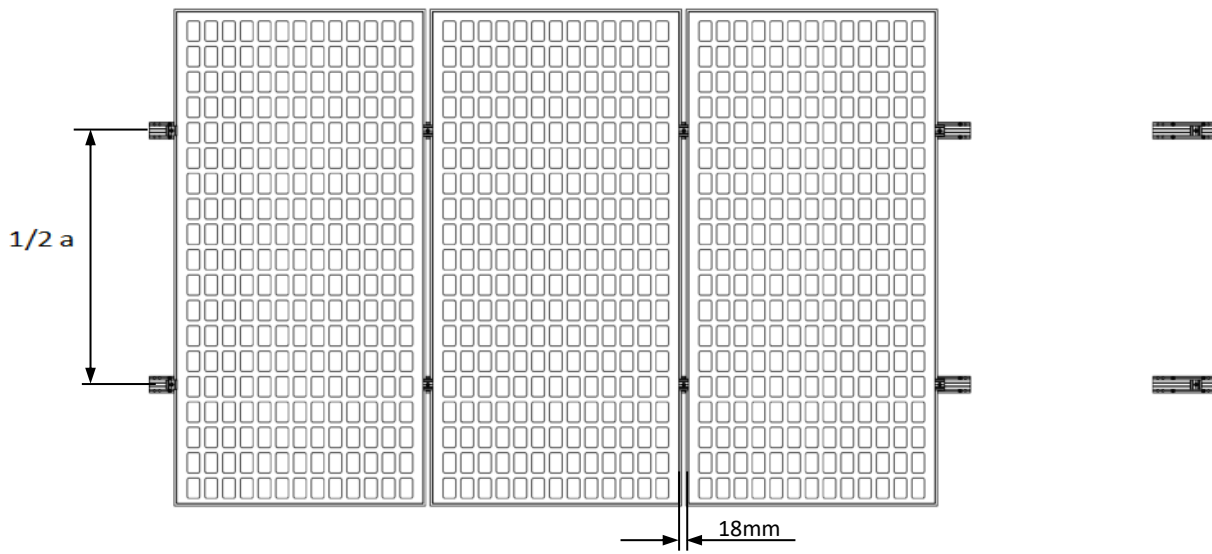

Solar panels layout

Installing Mini Rail

STEP.1 Use self-tapping screw (st6.3x25mm) to install the NSR mini rail. (Recommended torque: 9-11N.M) It is recommended to apply polyurethane (PU) waterproof glue to achieve complete waterproofing, if the roof involves perforated installation.

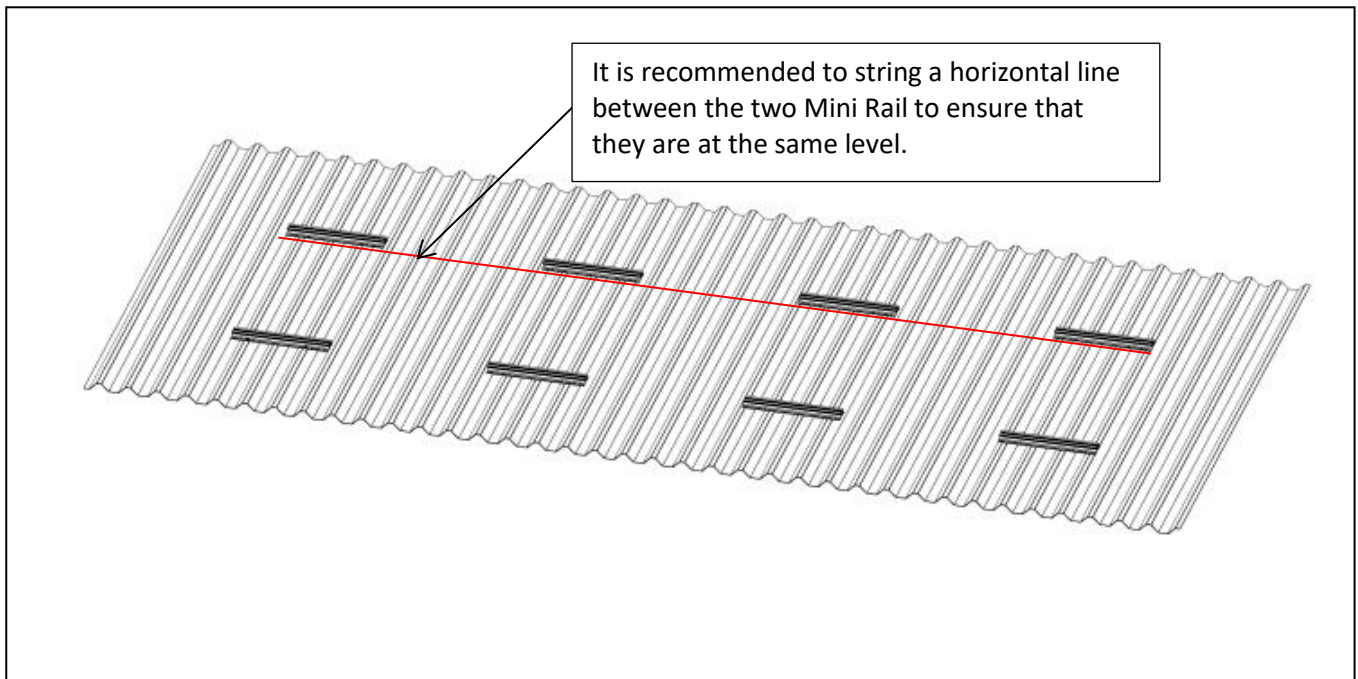
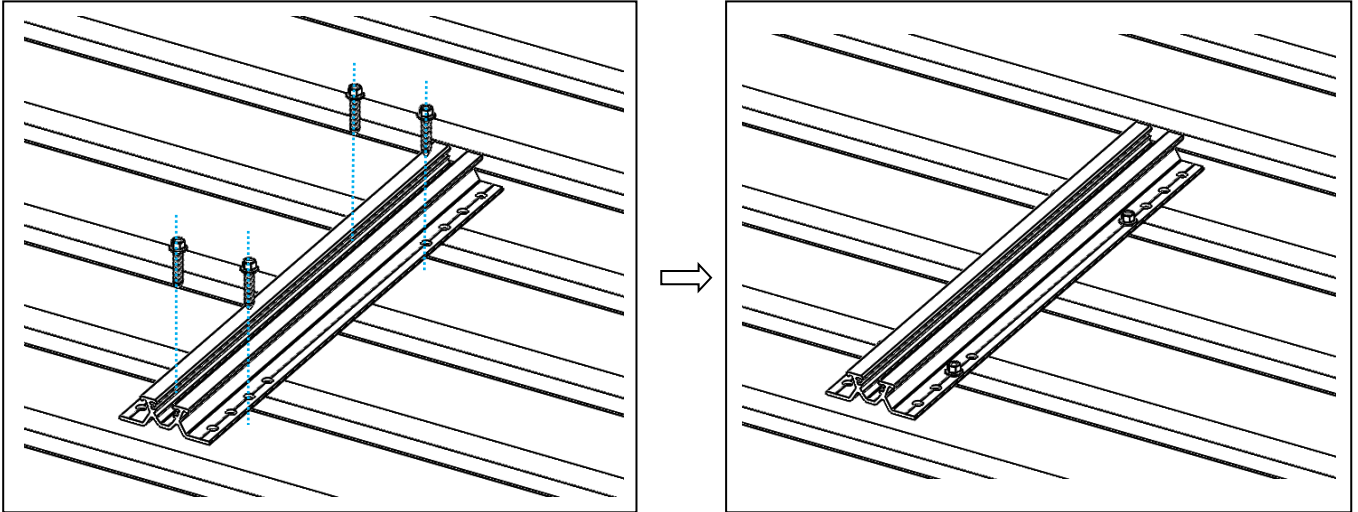

STEP.2 Install NOVA panel clamps.

When installing the first panel, adjust the position of the solar panel according to the technical drawings, secure the panel on the rails by the panel clamps.

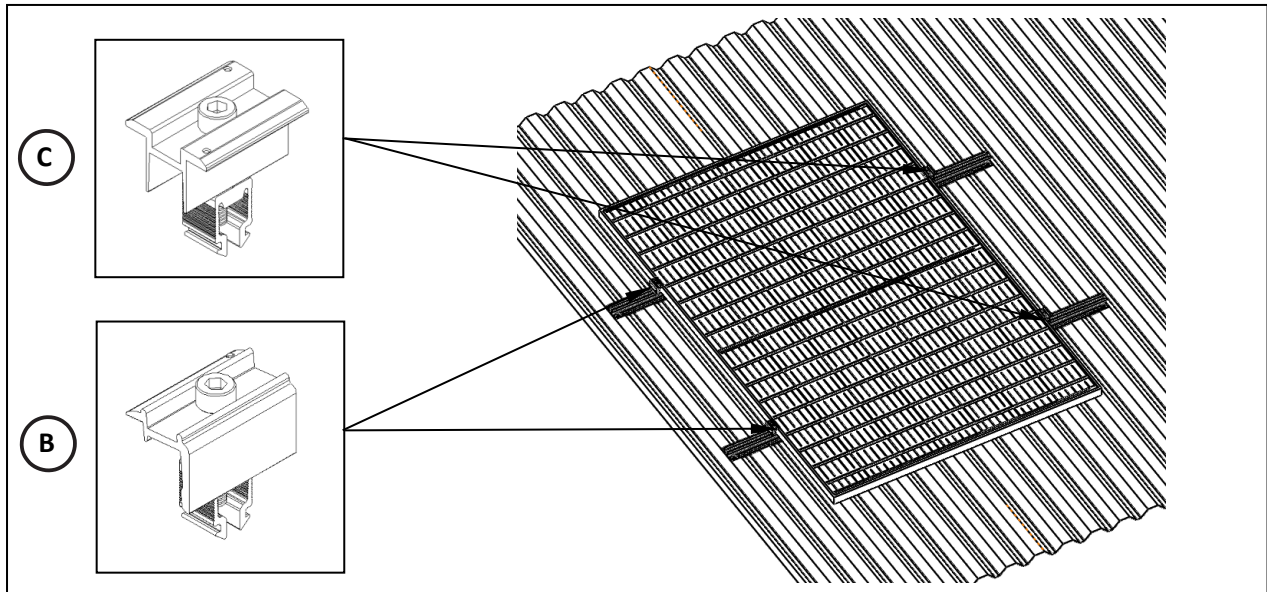

Slide/clip the clamp in to the rail.

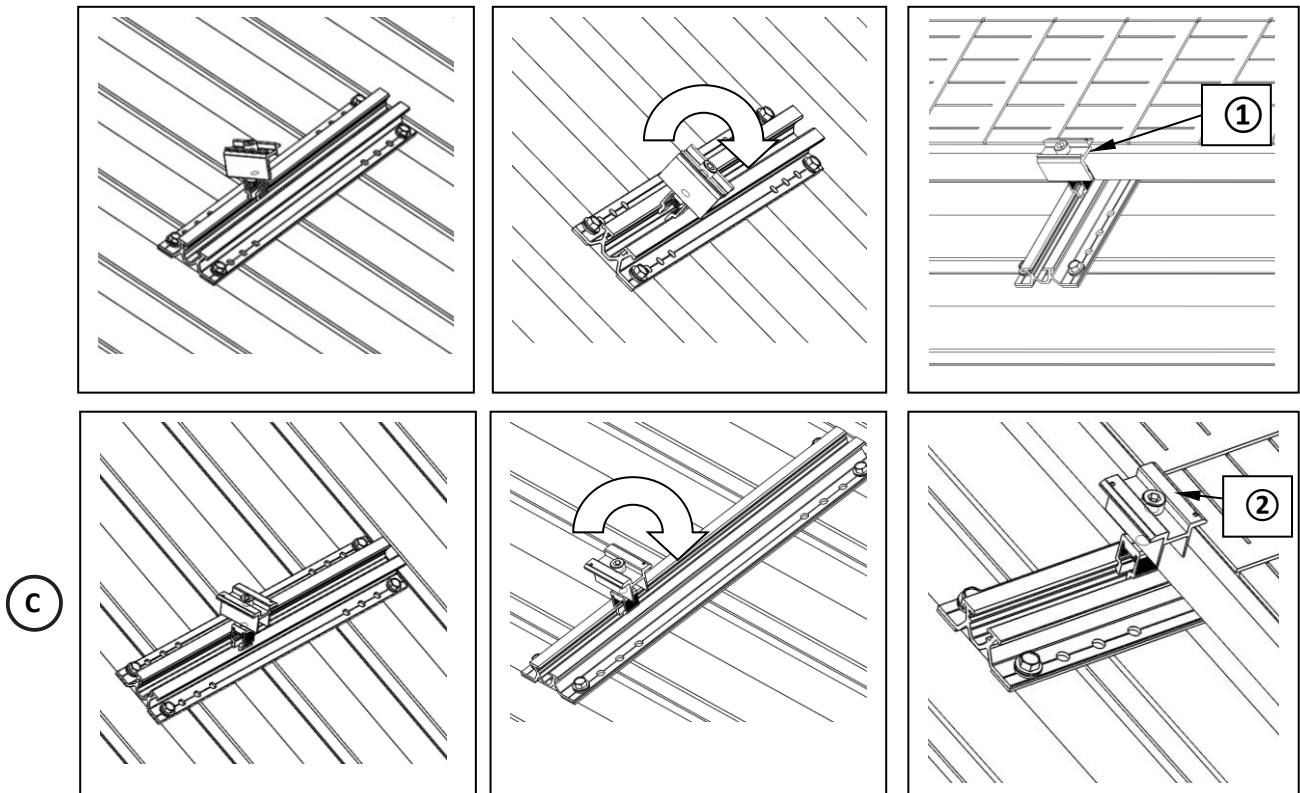

Attention:

- 1.The panel clamps close against the solar panel.
- 2.Tighten the bolt slowly, until the clamp in holding position.
- 3.Using 12-14N.M torque to tighten the bolt.

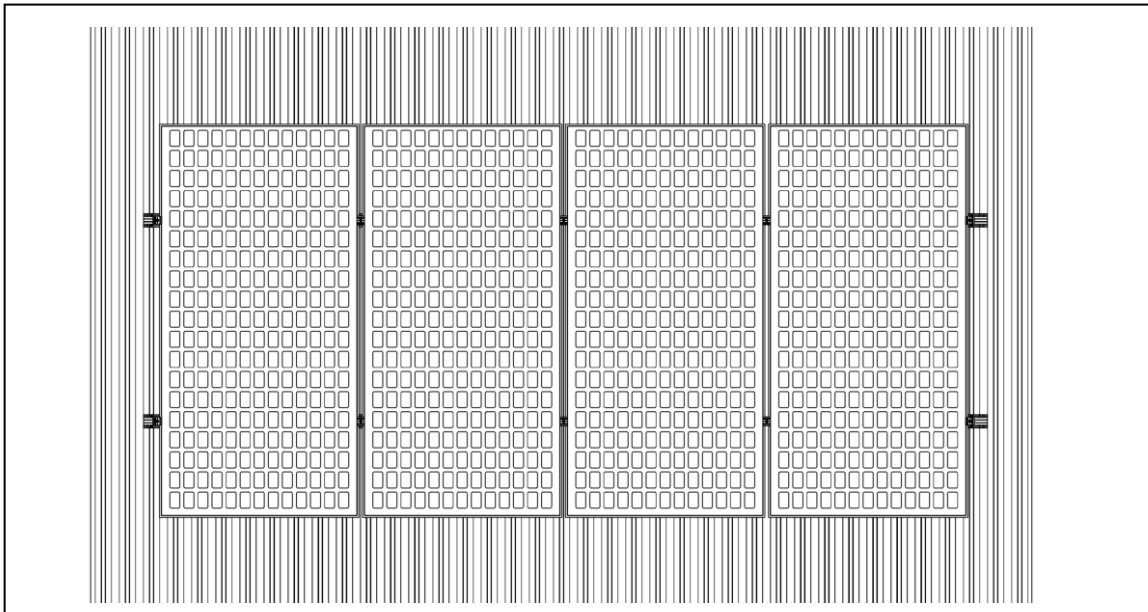
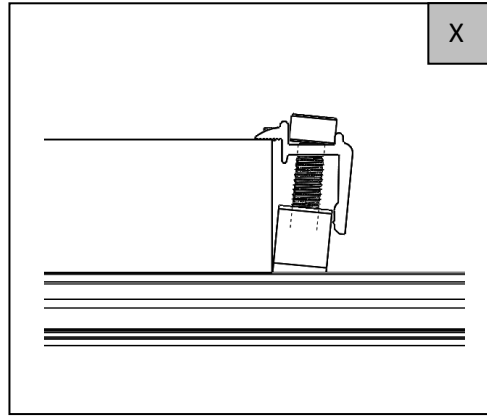
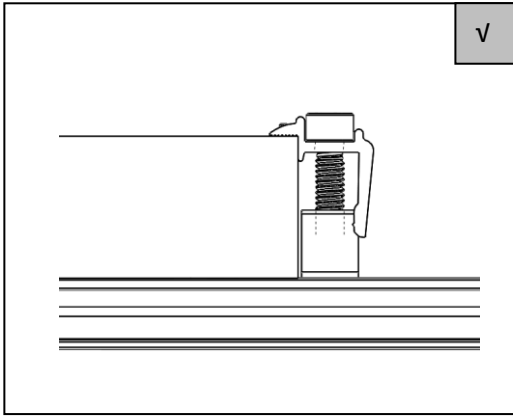

Components

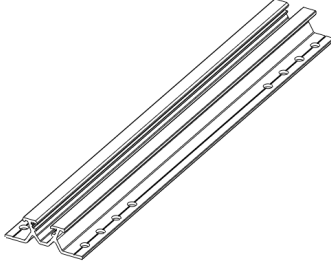
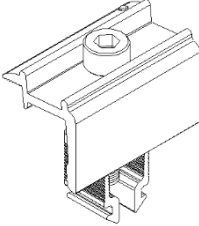
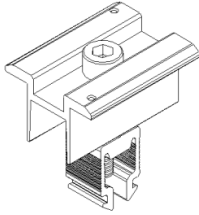
Part Name	Mini Rail Portrait	
Article #	920-122310	
Figure		
Part Name	NOVA Click End Clamp 30-40mm	NOVA Click Mid Clamp 30-35mm
Article #	930-991420	930-991410
Figure		



Regina Wautersweg 13, 8800 Roeselare
Belgium

+32 (0)51 14 05 94
hello@novamounting.com
www.novamounting.com

Rev.07082024